

The MW Series Wind turbine Owner's Manual

FOR

- MW-200 DC 12V MW-200 DC 24V
- MW-400 DC 12V MW-400 DC 24V



Product Serial Number : _____

Table of Contents

1. Safety Precautions.....	1
1.1 Mechanical Hazards	1
1.2 Electrical Hazards	1
2. Package Contents.....	2
3. Wiring.....	2
3.1 Electrical Connections.....	2
3.2 wire Size.....	3
3.3 Grounding/Lightning Protection	3
3.4 Fusing	4
3.5 Stop Switch.....	4
3.6 Ampere Meter	5
3.7 System wiring Diagram.....	5
4. Installation Procedures	6
4.1 Strongly Suggest.....	6
4.2 Precautions.....	6
4.3 Step-By-Step Instructions	7
4.4 Operation	8
5. Specification.....	9
5.1 Sphere of Operation.....	9
5.2 Specification	9

Powered by: MacroWind Small Wind Turbine Factory, Wuxi, China
Address: No.7 Qianzhangxiang, Wuxi City, China
E-mail: macrowind@gmail.com
Web Site: www.macro-wind.com

MacroWind is the trademark of MacroWind Small Wind Factory, Wuxi, China.

NOTICE:

1. This information is believed to be reliable; however, MacroWind Small Wind Turbine Factory assumes no responsibility for inaccuracies or omissions. **The user of this information and product assumes full responsibility and risk.**
2. All specifications are subject to change without notice.
3. Wind generators must be installed following the guidelines established by state and local regulations. Consult a local electrical contractor or the local planning and zoning office for details and regulations.
4. For your convenience and protection write the serial number of your wind turbine on the front of this manual. You will need this information in the event of a warranty claim. It also helps the customer service department at MacroWind Inc. when you have questions about your turbine. Thank you.

1. Safety Precautions

NOTE: Safety must be the primary concern as you plan the location, installation and operation of the turbine. Please be aware of electrical, mechanical and rotor blade hazards.

1.1 Mechanical Hazards

Rotating blades present the most serious mechanical hazard. The blades of **MW** turbines are made of very strong thermoplastic. At the tip, the blades may be moving at velocities over 220 Km/hour. At this speed, the tip of a blade is nearly invisible and can cause serious injury.

NOTE: Under no circumstances should you install the turbine where a person could come in contact with moving rotor blades.

CAUTION: DO NOT INSTALL THE TURBINE WHERE ANYONE CAN APPROACH THE PATH OF THE BLADES.

1.2 Electrical Hazards

Please be careful when connecting this and other electrical devices. Heat in wiring systems is often a result of too much current flowing through an undersized wire or through a bad connection.

CAUTION: SELECT THE CORRECT WIRE SIZE TO HELP AVOID THE RISK OF AN ELECTRICAL FIRE.

Batteries can deliver a dangerous amount of current. If a short occurs in the wiring from the batteries, a fire can result. Please choose a properly sized fuse or circuit breaker in the lines connecting to the battery.

CAUTION: FUSE ALL CONNECTIONS. SELECT THE CORRECT FUSE SIZE TO MINIMIZE THE RISK OF FIRE AND/OR AN ELECTRICAL FAILURE.

2. Package Contents

The **MW wind turbine** is shipped partially disassembled. Compare the parts shown in [Figure 1](#) to ensure that the contents of the box contain all necessary parts. And Refer to [Figure 1](#) for assembly instructions.

CAUTION: THE EDGES OF THE ROTOR BLADES ARE SHARP. PLEASE HANDLE WITH CARE.

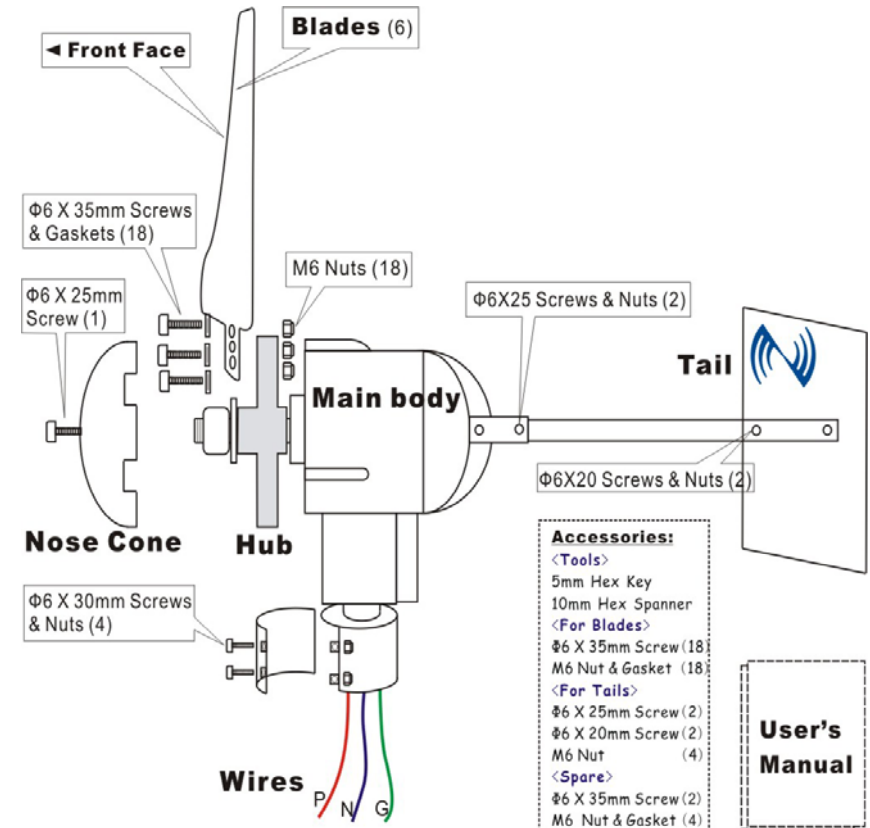

Figure 1: Package

3. Wiring

NOTE: Do not let the blade free until the turbine is mounted on the tower.

3.1 Electrical Connections

CAUTION: MAKE SURE THE TURBINE IS DISCONNECTED FROM THE

BATTERIES DURING INSTALLATION.

Avoid connecting different metals together (i.e., copper and aluminum). This will cause a galvanic cell that will erode one of the metals. When such connections cannot be avoided, consult an electrical supply house for anti-oxidant compounds. If possible **solder** wire termination ends.

CAUTION: CONNECTIONS SHOULD BE INSPECTED PERIODICALLY FOR SIGNS OF CORROSION AND CLEANED WHEN NECESSARY.

NOTE: All electrical power cables should be physically protected. Run the wires inside the tower or conduit for maximum protection.

3.2 Wire Size

All electrical systems lose energy from the resistance of the wires used. Larger wiring sizes have smaller losses. If cost is not an issue, a larger sized wire will improve the performance of your wind turbine. Measure the distance from the batteries to the wind turbine, then refer to the following chart as **minimum** wire sizes, to select the appropriate wire.

12V Wind Turbine: Wire Size (X-Section Area)

Distance From Batteries to MW	0-9M	9-18M	18-27M	27-45M
Wire X-Section Area (mm ²)	4	6	8	10

24V Wind Turbine: Wire Size (X-Section Area)

Distance From Batteries to MW	0-9M	9-18M	18-27M	27-45M
Wire X-Section Area (mm ²)	2.5	4	6	8

American Standard Wire Spec

AWG SIZE	14	12	10	8	6	4
Wire X-Section Area (mm ²)	2.68	3.31	5.26	8.37	13.3	21.1

3.3 Grounding/Lightning Protection

Properly grounding the turbine is **very important** for long-term operation. Grounding procedures must be followed along with any local electrical codes.

IMPORTANT: IMPROPER GROUNDING CAN CAUSE SEVERE DAMAGE! FAILURE TO PROPERLY GROUND WILL VOID YOUR WARRANTY.

It is very important to ground your battery bank and ground your tower for lightning and static protection. Proper grounding also enhances the safety of your turbine system. The green (GND) lead wire provides grounding for the body of the turbine. This wire must be connected to the system earth ground. This is usually done by connecting a wire from a ground rod near the base of the tower to the green turbine lead wire.

For additional lightning and static protection, another wire should connect this ground rod to the tower pipe.

The negative wire of your system should also be connected to a ground. This is usually done by connecting a wire from the negative battery terminal to a nearby ground rod. Wires with the same ratings as the positive and negative wires must connect all system grounds.

A grounding rod can be made for systems without an existing system ground from an 8 ft. (2.4 m) section of 3/4" (19 mm) galvanized pipe or conduit, or an 8 ft. (2.4 m) section of 5/8" (16 mm) iron or steel rod. This grounding rod must be buried completely beneath the soil, at no more than 45 degrees from vertical, or horizontally at least 2 1/2 ft. (75 cm) beneath the surface. It is recommended that the grounding rod be installed as close as possible to the batteries for maximum lightning protection. The base of the tower is also a good location for an appropriate surge arrestor.

3.4 Fusing

The **MW** wind turbine is capable of producing high amperages. As with all electrical installations, you must protect each of your turbines with a properly sized fuse or circuit breaker. The **MW** wind turbine should be wired with an appropriately sized "slow-blow" type fuse between itself and the batteries. If a stop switch is used, the fuse should be placed between the switch and the batteries.

Recommended Size for Circuit Breakers or Slow-Blow Fuses:

12V model: 20A DC

24V model: 10A DC

3.5 Stop Switch

A stop switch is not necessary, but sometimes useful. We recommend the use of a stop switch with your wind turbine to provide a convenient method for shutting down the turbine manually. A 20-amp single-pole double-throw switch will work as a stop switch for most applications. These switches should be wired as shown in *Figure 3*. The switch **disconnects the battery** and then **shorts the turbine wires** causing the turbine to stop spinning (in high winds the blades will spin slowly). Usually, shorting the turbine will not cause any damage or additional wear. But it should not be used for 12V turbines in very high wind (above 25m/s) applications for a long time.

NOTE: The center post must be positive from the turbine. Outside posts can be swapped as either battery positive or battery/turbine negative.

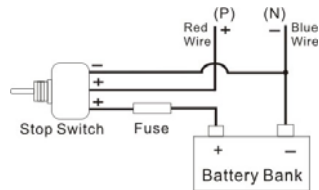

Figure 2: Stop Switch Wiring

NOTE: DO NOT accidentally connect the turbine “backwards” to the battery for even a second (i.e. turbine positive to battery negative). Doing this will damage the circuit inside the system.

3.6 Amp Meter

The Amp Meter can be placed in between the turbine and the battery on the positive lead. It will give you instantaneous readings of output in amps. The size is like:

	200W Turbine	400W Turbine
12 V	20 A	>= 30 A
24 V	>= 10 A	20 A

3.7 System wiring Diagram

While wind turbines are generating power, you need a good regulator (charge controller) to protect your storage batteries from overcharging and over-discharging damage.

The recommended way to connect the turbine to your battery bank is to wire the turbine through a regulator to the battery bank. Please see suggested system wiring diagram below.

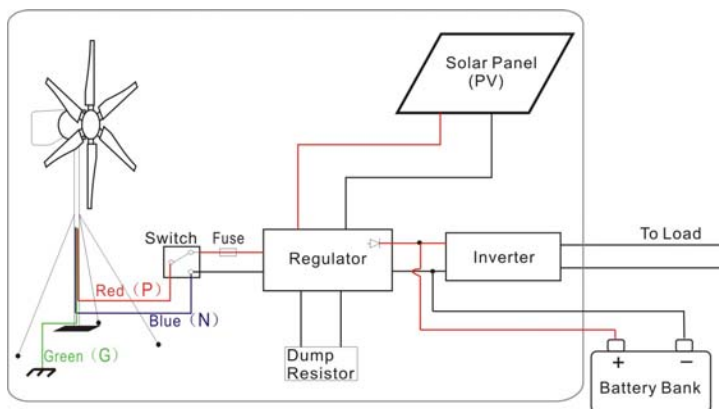

Figure 3: System Wiring

4. Installation Procedures

4.1 Strongly Suggest:

In the large wind area, the wind turbine has to be mechanically fastened. We need a through-bolt on the yaw when mount the turbine to the pole. Please follow the directions below.

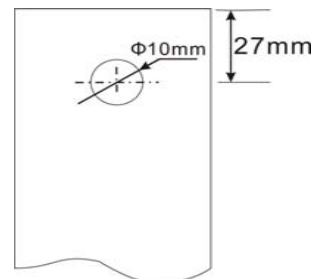

Figure 4: Hole on the pole

- A. Drill a hole through the tower using the diagram below.
- B. Feed system wires through tower and attach to turbine wires.
- C. Slide the yaw all the way down over the end of pole.
- D. Insert the 8 x 75mm long bolt through yaw and tower.
- E. Securely tighten 4 yaw screws.
- F. Tighten 8mm long bolt.

4.2 Please follow these precautions during the installation:

CAUTION: INSTALLATION PROCEDURES SHOULD BE PERFORMED AT GROUND LEVEL.

CAUTION: MAKE SURE THAT ALL BATTERIES ARE DISCONNECTED THROUGHOUT THE INSTALLATION PROCESS.

CAUTION: NEVER INSTALL THE MW TURBINE UPSIDE DOWN.

- Choose a calm day.
- THINK SAFETY! Have someone available to help during the installation process.
- Disconnect batteries from turbine wiring.
- Prior to attaching the wires to the battery, tie the wind turbine output lead wires (Positive = red <P>; Negative = blue <N>; Ground = green <G>) together near the battery to be sure that the rotor will not spin-up during installation.
- Be careful not to pinch the wires when attaching the turbine to tower.
- Make sure a minimum **50 mm** clearance must be given between the blade tips and any obstructions. Refer to *Figure 1* below.

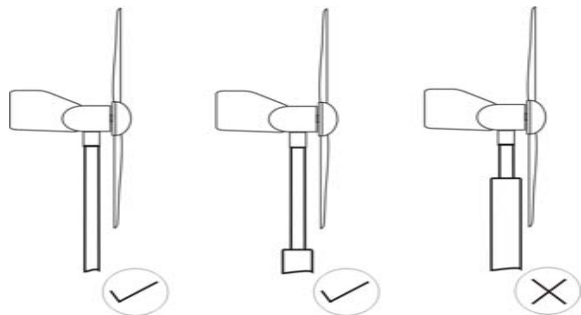

Figure 5: The clearance between the blade and pole

NOTE: Do not install the blade until the turbine is mounted on the tower.

4.3 Step-By-Step Instructions

The following *Step-By-Step-Installation-Procedures* provide you with an outline of the MW wind turbine installation process. Please refer to figure 1 while assembling.

- 1) Run the wires from the regulator (usually put the regulator near the battery), through the pole to the **top** of the tower. **Be sure not to connect the wires to the battery until everything else has been completed.**
- 2) Strip the insulation back from each set of wires.
- 3) Mark both ends of all the wires with tape to identify which is positive, negative and earth ground.

Red = Positive (P)
Blue = Negative (N)
Green = Ground (G)

- 4) Connect the wires from the wind turbine to the wires running to the regulator. Insulate the connections using either heat shrink tubing or a quality electrical tape.

CAUTION: If you are uncertain of the polarity of the wires, simply spin the rotor shaft and measure the voltage direction with a volt meter.

- 5) Once the wires are attached to the turbine, gently pull the wires down through the tower sliding the yaw shaft over the steel pipe (**OD 50-51mm**). **Do not use plastic pipe.**
- 6) Slide the yaw shaft all the way down over the end of pole being careful not to pinch the yaw wires. Be sure to leave enough slack in the wires so that if necessary, the turbine can be removed.
- 7) After the yaw is all the way onto the pole, move it back up 2 mm to prevent the bottom of the yaw from contacting the top of the pole.

- The only contact between the tower and yaw is through the outside of the pole. It will reduce the transmission of noise down the tower.
- 8) Once the yaw shaft is on the tower, firmly tighten the yaw clamp screws with the tools.
 - 9) Make sure that your wind turbine is securely attached to the mounts. Remember that this attachment will have to hold in high winds.

CAUTION: Make sure the front face of the blade is toward the wind. (The straight edge of the blade should be on the right when fixed to the hub.)

- 10) Put the nose cone to the head of the shaft.
- 11) Run all wires from the turbine to the regulator. Attach your positive (Red) wire to a fuse. Refer to fusing Section or figure 2.
- 12) Attach wires to the Regulator. Red wire to positive, blue wire to Negative. (Or follow the manual of the regulator.)
- 13) Make sure that your system is properly grounded before proceeding. Refer to the Grounding Section.

IMPORTANT: SEVERE UNIT DAMAGE MAY RESULT FROM IMPROPER GROUNDING. FAILURE TO PROPERLY GROUND THE TURBINE WILL VOID YOUR WARRANTY.

- 14) Before attaching the wiring from regulator to the battery, make sure:
 - All circuit breakers are in the off position
 - The stop switch is in the "stop" or shorted position (if installed)
- 15) Attach wires to the battery. Red wire to Positive, blue to Negative.
- 16) Turn on the stop switch if you have installed one.
- 17) You have now completed the installation process.

4.4 Operation

Check support structures, blades, and electrical systems.

- Do not let the rotor blades come in contact with a solid object. Use common sense about safety when locating the turbine.
- When performing periodic inspections, or at anytime when you must approach the path of the blades, disconnect the power leads from the battery and tie the wind turbine output leads together to **stop (slow down)** the blades from rotating. The turbine can also be shut down through the use of a stop switch. Please refer to Figure 2 on how to install a stop switch in your system.
- Please note that there is a short break-in period with new turbines. The bearings will require approximately 100 hours of operation in normal wind speeds before they are running at peak efficiency.

CAUTION: NEVER APPROACH THE TURBINE DURING OPERATION.

NOTE: USE COMMON SENSE AND PLEASE BE CAREFUL.

5. Specification

5.1 Sphere of Operation

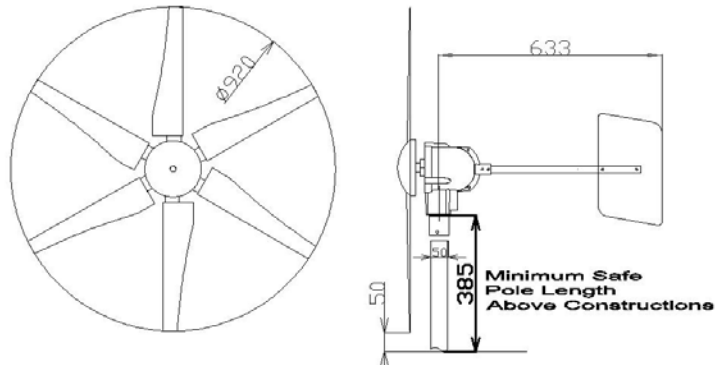

Figure 5: Sphere of Operation for MW-200

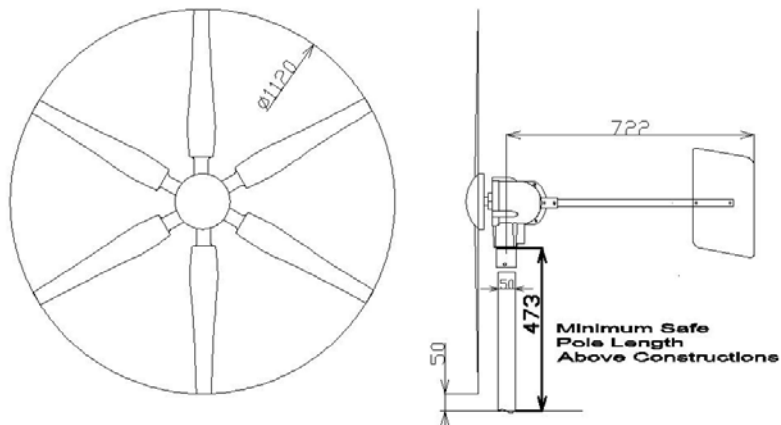

Figure 6: Sphere of Operation for MW-400

5.2 Specification

MW-200	MW-200	MW-400
Rotor Diameter	0.92 M	1.12M
Weight	8.5 Kg	11.5 Kg
Cut-in Wind Speed	2.3 M/S	2.1M/S
Rated Power	150 W	250W
Max Power	200W	400W
Pole Dimensions	OD 48-51 mm	OD 48-51 mm