

User Manual

– (Wind Controller 12/24V For MW wind turbine)

1. Notice:

- This is a simple switch mode wind charge regulator with the optional dump connectors, and is designed for MW Series Wind Turbine only.
- We support this controller only for our small windmill users, to lower the total cost of their renewable power system.
- Use the corresponding voltage rating model for the 12V or 24V system.
- Do not exceed the current rating (20A).

- For a wind turbine only, please follow the Figure 3. Be careful to connect the wires and connectors correctly.
- In a wind & solar hybrid power system, users can use a solar controller with this wind controller, and just use the solar controller to control the load. A solar controller is cheap, so users need not pay for the expensive hybrid controller. (See Figure 4.)

About Dump



- The MW wind turbine has an auto-protect circuit inside. It does not have to work with a dump load (dump resistor).
- Some users like to use the extra power from the wind turbine to heat the water or light a lamp, then they can use them as the dump and connect to the dump connectors.
- The charge current from wind turbine is not steady as the wind is always change. A dump resistor can help to absorb the extra power and make the battery fully charged.

Use a Dump Resistor:

- 3 Ohms or above/100W or above for 12V Model
- 10Ohms or above/100W or above for 24V Model

2. Diagram

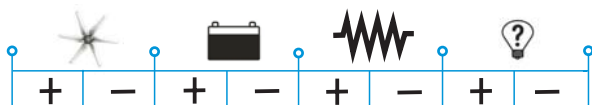

Connectors

(From Left to Right)

1. To Wind Turbine '+'
2. To Wind Turbine '-'
3. To Battery '+'
4. To Battery '-'
5. To Dump Load '+'
6. To Dump Load '-'
7. To Load '+'
8. To Load '-'

LED Indicator

(The LED light, from left to right)



- **Green 'ON'** when battery is well connected.
- **Green 'OFF'** when battery is not connected correctly.



- **Red 'OFF'** when battery voltage is OK, and the dump load will not work (if there is one).
- **Red 'ON'** when battery is about full, and the dump load will work (if there is one).



- **Green 'ON'** when load can be supplied.
- **Green 'OFF'** when battery is over-discharged and the load can not be supplied.

3. Connect the wires

Wind power system (only a wind turbine)

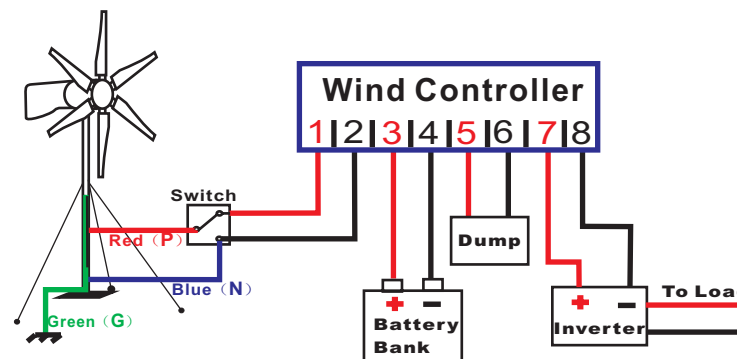

(Figure 3. Wind Charge System Circuit Diagram)

- The switch is optional.
- First, please connect the battery '+' and '-' to the correct connectors. And the left led (green) will light-on.
- Second, please connect the wind turbine '+' (red wire) and '-' (blue wire) to the correct connectors.
- Third, please connect the load '+' and '-' to the correct connectors.
- Then, connect the dump if you want. Choose a right dump resistor or any other water heat or lamp.

Wind & solar hybrid power system

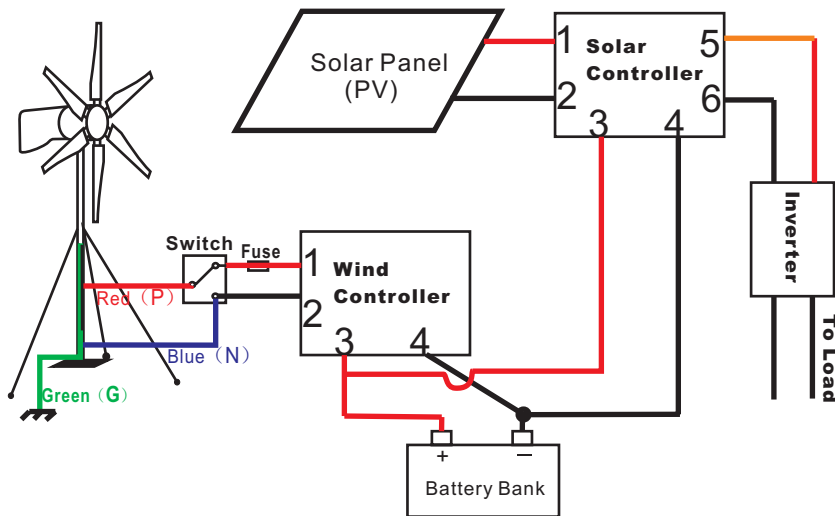

(Figure 4. Wind & Solar Hybrid System Circuit Diagram)

- The switch is optional.
 - Connect the battery '+' and '-' to the **wind controller**.
 - Connect the wind turbine '+' (red wire) and '-' (blue wire) to the **wind controller**.
 - Then, connect the dump if you want.
 - Connect the battery '+' and '-' to the **solar controller**.
 - Connect the solar PV '+' (red wire) and '-' (blue wire) to the **solar controller**.
 - Connect the load '+' and '-' to the **solar controller**.
- Sometimes a inverter is needed to get proper AC power for your load.

To correct the problem:

- Check the Fuse.
- Check the wires and the connectors.
- Reduce amps if needed.

4. Specification

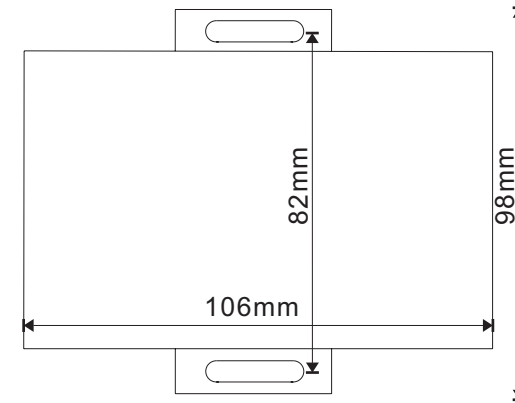

Technical Information:

- 12V/20A Model: For MW200-12V or MW400-12V
- 24V/20A Model: For MW200-24V or MW400-24V
- Terminals for wire sizes to 6mm
- Weights 200g
- Dimension 85*65*35mm
- Self-consumption 6mA maximum
- Temperature -35°C to 55°C
- Enclosure Ip22
- Warranty 1 Years

		12V Type	24V Type
Battery Disconnect	(Over-Charged)	16.1V	32.2V
Battery Reconnect		14.7V	30.3V
Dump Load Connect		15.7V	31.4V
Dump Load Disconnect		13.9V	28.8V
Low voltage Disconnect	(Over-Discharged)	11.0V	22.0V
Low voltage Reconnect		12.2V	24.0V

Note:

- After over charged, the controller will resume to work when the battery is back to 14.7V (or 30.3V for 24V battery).
- After over discharged, the controller will resume to work while the battery voltage is over 12.2V (24V for 24V battery) .